

ROTATING ELECTRICAL CONNECTOR

旋轉連接器 水銀式電氣滑環

New

Non - Mercury Slip Rings 非水銀滑環
CE RoHS Meets Liquid Metal
使用符合CE RoHS 導電液態金屬



- Very low electric noise
- Very low cost
- Very low contact resistance
(Less than $1m\Omega$)
- No maintenance and better reliability
than traditional slig rings
- Suitable for signal and power transfer
of rotating devices or instruments

- 無雜訊
- 低單價
- 小於 $1m\Omega$ 之接觸電阻
- 不必保養，比傳統式滑環更耐用
- 適合用於任何旋轉體之信號及電力接續

Asiantool®

Construction & Function 構造&功能

The Asiantool rotating electrical connectors are using the special insulation, sealings, and conductive technologies.

The out case material is the aluminum alloy or stainless steel.

They are used for any kind of rotating objects of signals like micro voltage, current, EMF, thermo couple, strain gauge, audio, video, high frequency etc and electric power connections.

All types can fill CE RoHS liquid metal, please contact us, for details.

Asiantool 旋轉連接器利用特殊密封，絕緣及導電技術製成，其外殼為陽極處理鋁合金或不鏽鋼材料。

用於任何旋轉體之信號如微小電壓、電流、EMF、熱電偶、Strain gauge、影音訊號、高頻、電腦訊號及電力的接續。另有符合CE RoHS 規格之產品，請來電洽談。

Application 用途

- Index table for signal and power connection
- Wind Turbines
- 旋轉工作盤之信號及電力之接入
- Resistor cutting machine
- Electro plating line
- 旋轉鍍銀線
- Speed dome camera
- Rotary stage
- 旋轉攝影機
- Package machine
- Cable wheel
- 包裝機
- Heating roller
- Circle knitting machine
- 熱滾輪
- Lamilating
- Coloring device
- 壓模機
- Winding machine
- Robots
- 繞線機
- Spinning LED sign board
- Rotary lamp box
- LED廣告燈
- Medical Equipments
- 機器手臂
- 風力發電機
- 旋轉燈箱
- 管內攝影機

Specification 規格

Model 型號	Conductor Poles 極數	Current Amp. 電流	Voltage AC/DC V 耐壓	Max. Freq. MHZ 頻率	Max. RPM 最大轉速	Operating Temp. Max/Min °C 使用溫度	Rotating Torque (gm-cm) 轉矩	Insulation Resistance 絕緣阻抗
A1M	1	10		200	3600	60/-30	35	
A1MT	1	10		200	3600	60/-30	35	
A1M2	1	20		200	2000	60/-30	50	
A1M5	1	50		200	1800	60/-30	70	
A1HH	1	250		200	1200	60/-30	250	
A1H25S	1	250		200	1200	60/-30	250	
A1H25PS	1	250		200	1200	60/-30	250	
A1H35S	1	350		200	800	60/-30	300	
A1H50PS	1	500		200	300	60/-30	700	
A1H65S	1	650		200	200	60/-30	1000	
A1H65PS	1	650		200	200	60/-30	1000	
A1H90PS	1	900		200	200	60/-30	1100	
A1H150PS	1	1500		200	100	60/-30	2000	
A1H300PS	1	3000		200	60	60/-30	3000	

Model 型號	Conductor Poles 極數	Current Amp. 電流	Voltage AC/DC V 耐壓	Max. Freq. MHZ 頻率	Max. RPM 最大轉速	Operating Temp. Max/Min °C 使用溫度	Rotating Torque (gm-cm) 轉矩	Insulation Resistance 絕緣阻抗
A1H500FS	1	5000		200	50	60/-30	4000	
A1H750FS	1	7500		200	50	60/-30	6000	
A2S	2	4	250	200	2000	60/-30	75	> 25MΩ
A3S	3	4	250	200	1800	60/-30	100	> 25MΩ
A3S-W	3	4	250	200	1800	60/-30	100	> 25MΩ
A4S-W	4	4	250	200	1200	60/-30	150	> 25MΩ
A2H	2	30	250	200	1800	60/-30	200	> 25MΩ
A3M	3	30/4	250	200	1800	60/-30	200	> 25MΩ
A3M-W	3	4	250	200	1800	60/-30	200	> 25MΩ
A3H	3	30	250	200	1200	60/-30	400	> 25MΩ
A4H	4	30/4	250	200	1200	60/-30	400	> 25MΩ
A6H	6	30/4	250	100	300	60/-30	700	> 25MΩ
A8H	8	30/4	250	100	200	60/-30	1000	> 25MΩ
A1030	10	30/4	250	100	100	60/-30	1500	> 25MΩ
A1230	12	30/4	250	100	60	60/-30	2000	> 25MΩ
A1430	14	30/4	250	100	60	60/-30	2000	> 25MΩ
A2H6	2	60	250	200	600	60/-30	400	> 25MΩ
21005W	7	100/4	250	100	100	60/-30	1500	> 25MΩ
A2HV	2	30	500	100	400	60/-30	400	> 50MΩ
A3HV	3	30	500	100	300	60/-30	700	> 50MΩ
A4HV	4	30	500	100	200	60/-30	1000	> 50MΩ
A5HV	5	30	500	100	100	60/-30	1500	> 50MΩ
A6HV	6	30	500	100	60	60/-30	2000	> 50MΩ
A7HV	7	30	500	100	60	60/-30	2000	> 50MΩ

Through-bore type 中空式

Model 型號	Through -bore φ 中空孔徑	Conductor Poles 極數	Current Amp. 電流	Voltage AC/DC V 耐壓	Max. Freq. MHZ 頻率	Max. RPM 最大轉速	Operating Temp. Max/Min °C 使用溫度	Rotating Torque (gm-cm) 轉矩	Insulation Resistance 絕緣阻抗
H23016	16.2mm	2	30	250	100	100	60/-30	1000	> 25MΩ
H43016	16.2mm	4	30	250	100	60	60/-30	1500	> 25MΩ
H63016	16.2mm	6	30	250	100	40	60/-30	2000	> 25MΩ
H83016	16.2mm	6	30	250	100	40	60/-30	2000	> 25MΩ
H23010	10.2mm	2	30	250	100	150	60/-30	2000	> 25MΩ
H43010	10.2mm	4	30	250	100	100	60/-30	2000	> 25MΩ
H63010	10.2mm	6	30	250	100	60	60/-30	2000	> 25MΩ
H83010	10.2mm	8	30	250	100	40	60/-30	2000	> 25MΩ
H103010	10.2mm	10	30	250	100	40	60/-30	2000	> 25MΩ

Boots Kit 保護套

- A4H-BK for A4H, A3H
- A6H-BK for A6H
- A8H-BK for A8H



Notice 注意事項

- Not exceed the Max. temperature 60°C(140°F), room temperature + self heating. (rotate + electric connection)
- Vertical mounting and storage should keep the  in the up direction
- Mounting into a shaft should keep no eccentricity.
- Do not solder on the connector and terminal.
- Connect the connector on the terminal only a few times, losing connection will cause heating when apply electric power.
- Vibration will cause service life shorter.
- The rotary connector can be mounted by the body or plastic collar but it can not carry mechanical loads. Another end should be conneted floating hold by electric wire.
- The uppers notice should be kept, otherwise it will cause the rotary connector failure or shorten service life.

Application 應用實例

Index table 旋轉工作盤

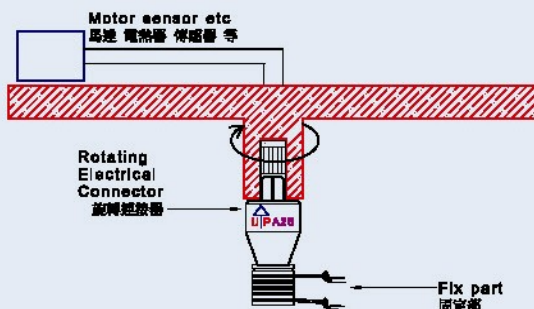

Terminals & Shrink Tube 端子 & 熱縮套管

- SY28
- SR28
- SB63
- S63
- LB63
- LLB63
- LLB63C
- SK3



- 使用溫度不超過60°C，周圍溫度+自體發熱（旋轉+通電）。
- 垂直方向安裝時，要保持標誌  向上，保存時亦需保持向上。
- 安裝旋轉連接器於軸心時不可偏心，裝上止扣螺絲時最好採用3點止扣方式。
- 不可對旋轉連接器本體或銅端子焊接加熱。
- 專用之連接端子不可重覆使用多次，鬆動後接觸不良而發熱。
- 旋轉體如振動會降低使用壽命。
- 此連接器可以鋁外殼或塑膠部份裝入軸心固定後，再以插入端子電線拉住轉動部即可，一頭固定於軸心，一頭浮拉於外固定部，但決不可以承受重量。
- 以上事項如不遵守會對旋轉連接器產生不同程度之損壞或降低使用壽命。

Cable wheel 電纜卷筒

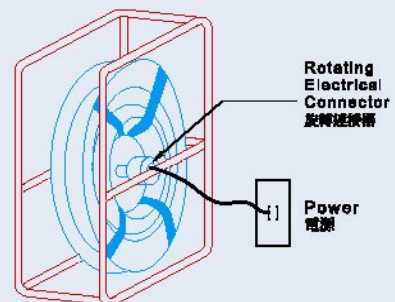

Model, Size, accessories 形式、尺寸及附件

A1M 1pole 10A

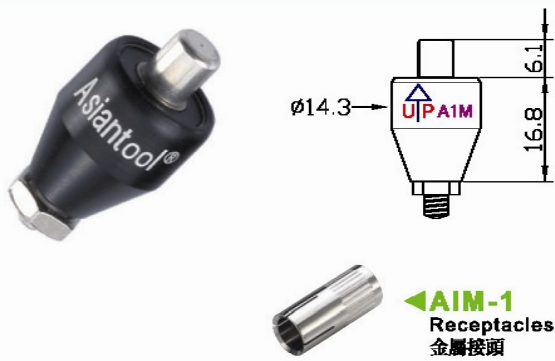

● Mounting 安裝

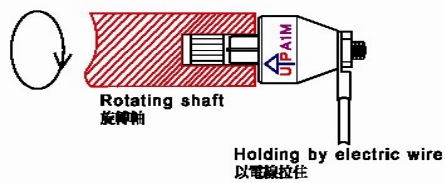

A1MT 1pole 10A

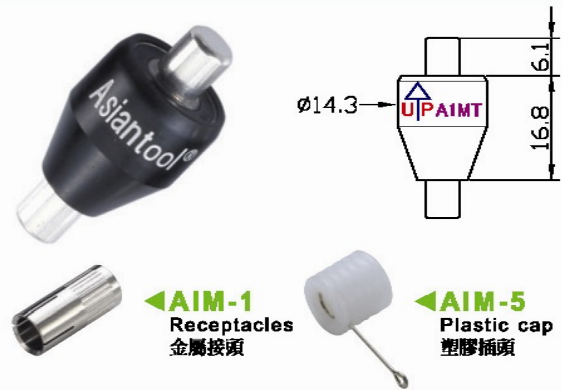

● Mounting 安裝

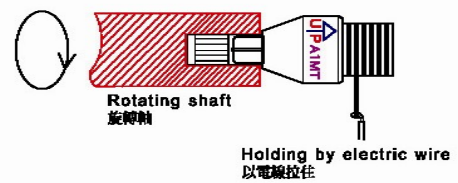

A2S 2poles 4A



● Mounting 安裝

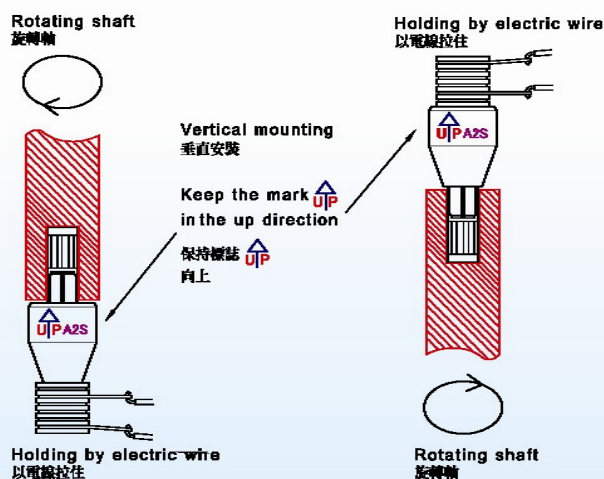

A3S 3poles 4A



● Mounting 安裝

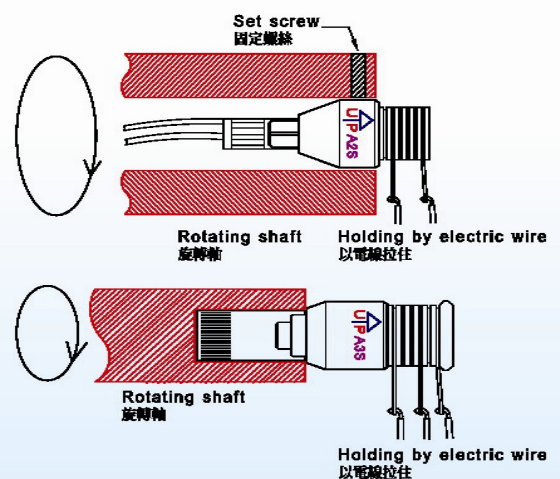

A1M2 1pole 20A

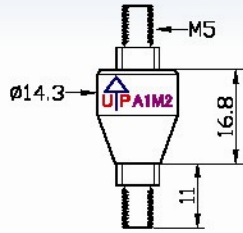

● Mounting 安裝

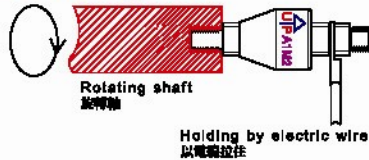

A1HH 1pole 250A

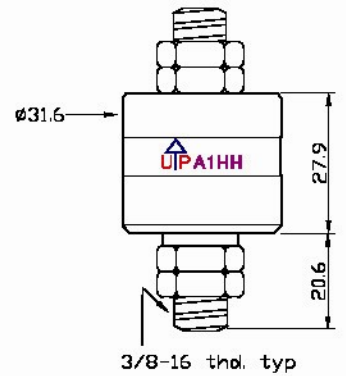

A1H25S 1pole 250A

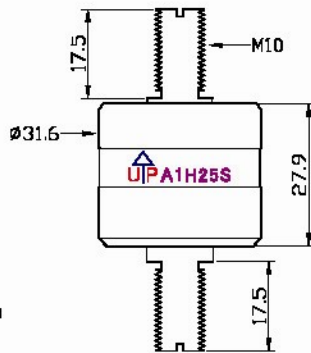

Stainless steel shell and SS bearing
不銹鋼外殼
不銹鋼軸承

A1H25PS 1pole 250A

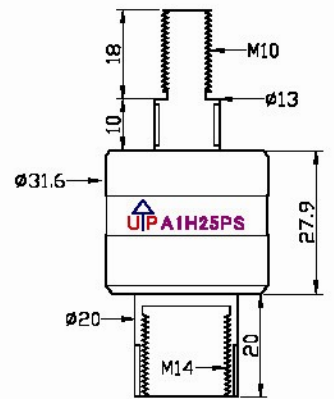

Stainless steel shell and SS bearing
不銹鋼外殼
不銹鋼軸承

A1H35S 1pole 350A

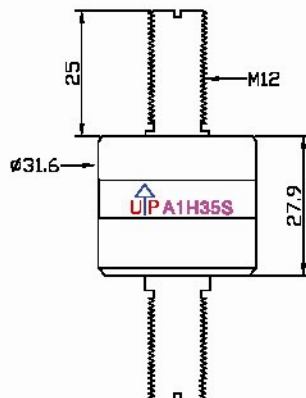

A1H65PS 1pole 650A

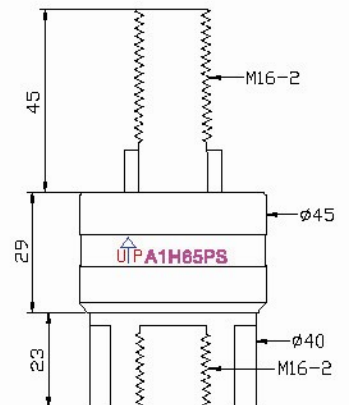

A1H150PS 1pole 1500A

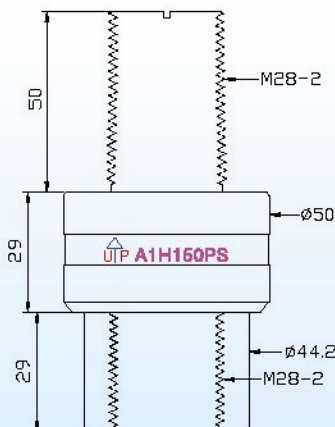

● Mounting 安裝

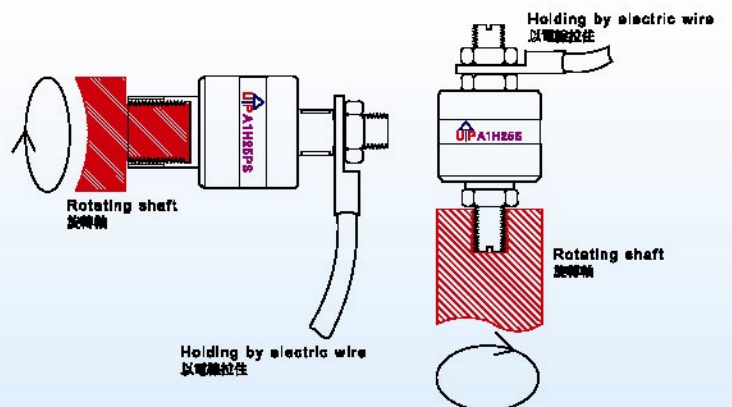

Model, Size, accessories 形式、尺寸及附件

A2H 2poles/30A/AC250V

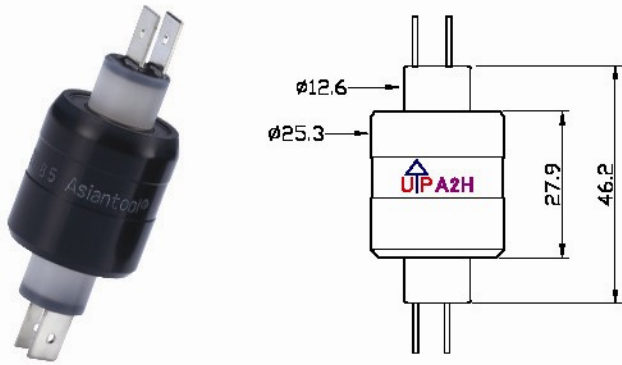

A3M 1poles/30A & 2poles/4A AC250V

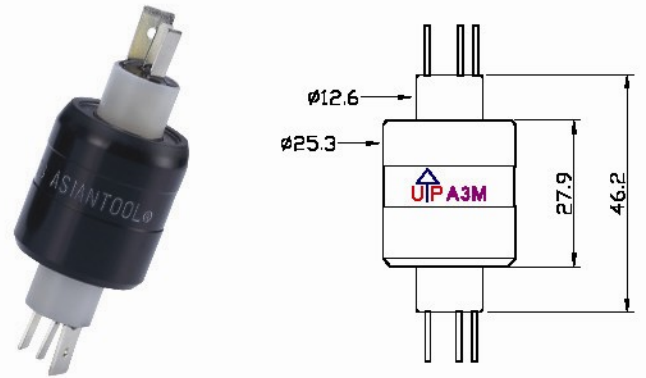

A3H 3poles/30A/AC250V

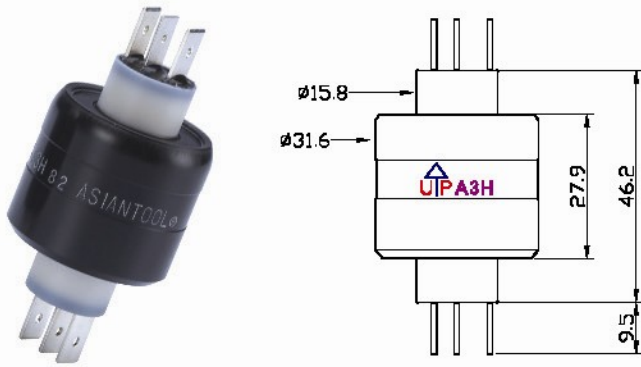

A4H 2poles/30A & 2poles/4A AC250V

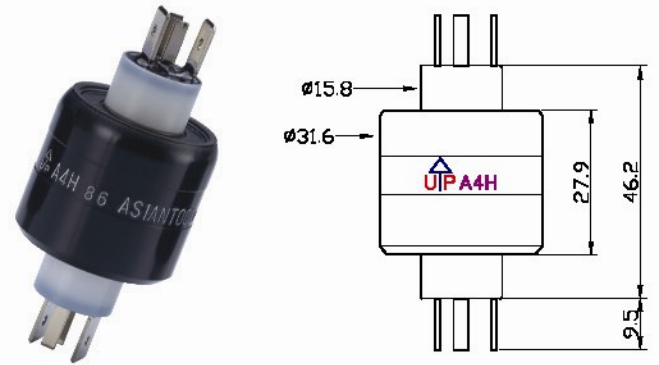

A6H 4poles/30A & 2poles/4A AC250V

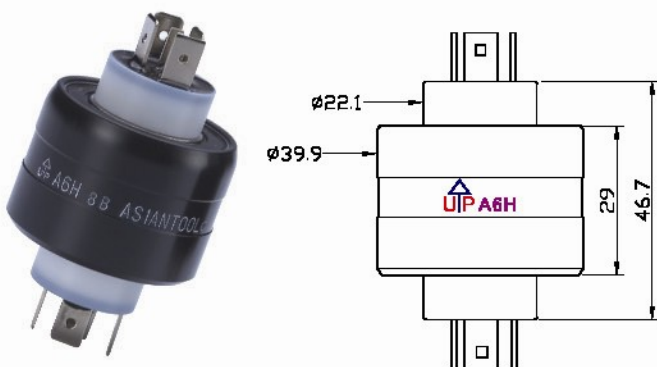

A8H 6poles/30A & 2poles/4A AC250V

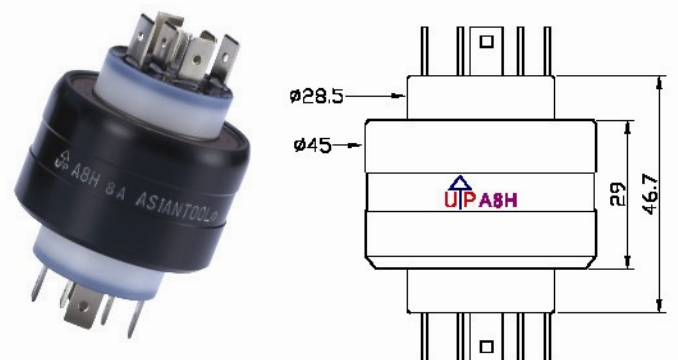

A2H6 2poles/60A/AC250V



Mounting 安裝

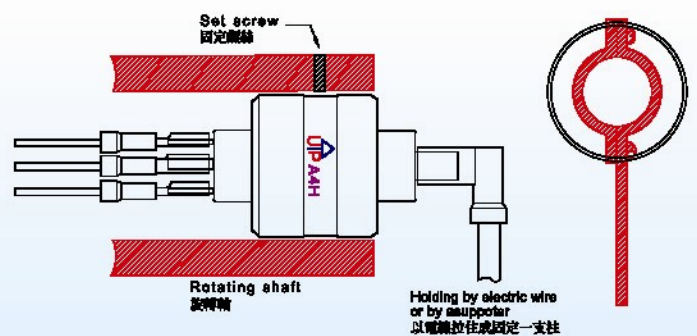

Model, Size, accessories 形式、尺寸及附件

**A1030 8poles/30A & 2poles/4A
AC250V**

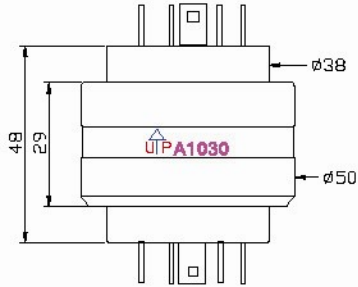

**A1230 10poles/30A & 2poles/4A
AC250V**

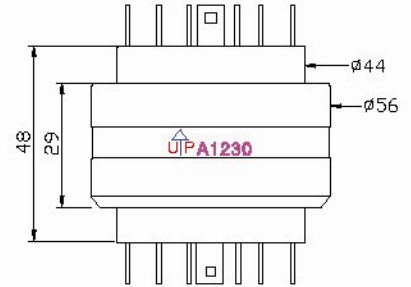

**A1430 12poles/30A & 2poles/4A
AC250V**

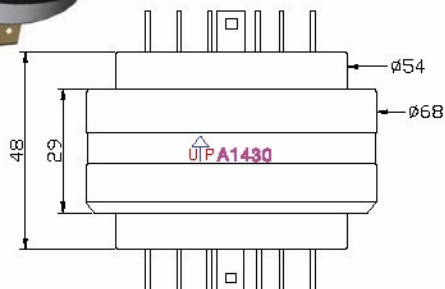

**H83016 Through-bore=16.2mm
8poles/30A 中空孔徑**

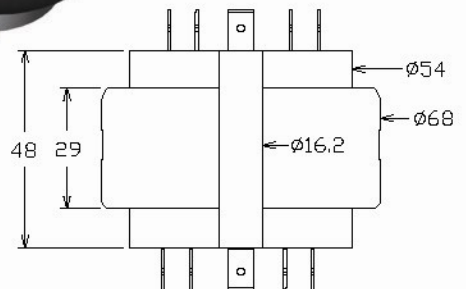

**21005W 5poles/4A-20A &
2poles/80A-150A
AC250V**



A3M-W 3poles/4A/AC250V



We also produce any other customers made slip rings. Please contact us.
我們亦承製任何客製化旋轉連接器，請和我們連絡。